



LED Hi Bay – 100W

Model: SLA-HBHS2-100W

LED Hi Bays are suitable for factories, workshops, basketball courts, stadiums, commercial buildings.

Product Features

- 120° Round Beam Angle, but adjustable
- Aluminium die cast housing
- Toughened glass face
- Long operating life and performance
- With Built In Sensor & Remote Control
- IP65 Waterproof housing

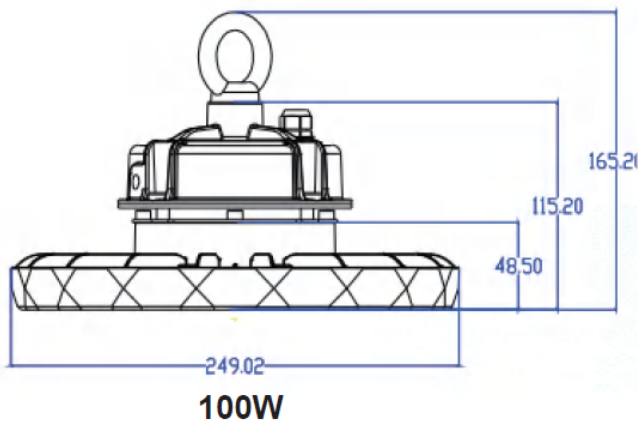
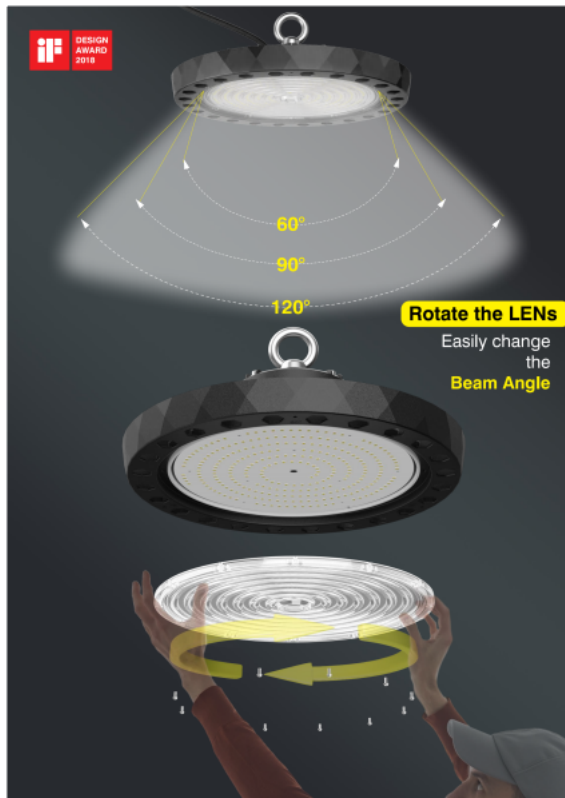

SPECIFICATION

Colour	Cool White (5500K)
Lumen (lm)	19.000lm
Efficiency (Lm/w)	>190lm/w
Light Source	LED
CRI (%)	>80%
Beam Angle	120° or can change to 60° or 90°
Power Requirement	AC 220~240V
Power Consumption	100W
Housing	Die Cast Aluminium and Toughened Glass
Lifespan	> 50,000 hours
Operation Temperature	-20°C~+60°C
Dimension (mm)	249 x 165mm
Sensor	Yes
Protection Rating	IP65
Warranty	5 years